

USN

--	--	--	--	--	--	--	--

15CV62

Sixth Semester B.E. Degree Examination, Dec.2018/Jan.2019 Design of Steel Structural Elements

Time: 3 hrs.

Max. Marks: 80

- Note:** 1. Answer any FIVE full questions, choosing one full question from each module.
2. Use of IS800-2007 and Steel tables permitted.

Module-1

- 1 a. Mention the failure criteria of steel with examples. Explain any one in brief. (10 Marks)
 b. Explain briefly class 1, class 2 and class 3 sections. (03 Marks)
 c. Name the following elements: (03 Marks)

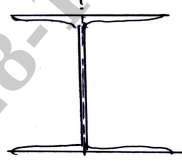

Fig.Q1(c)i



Fig.Q1(c)ii

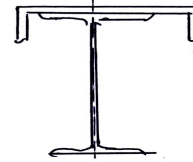

Fig.Q1(c)iii

OR

- 2 a. Determine the shape factor for the section shown in Fig.Q2(a), if permissible yield stress in compression and tension is 200 MPa. and 240 MPa respectively. (06 Marks)

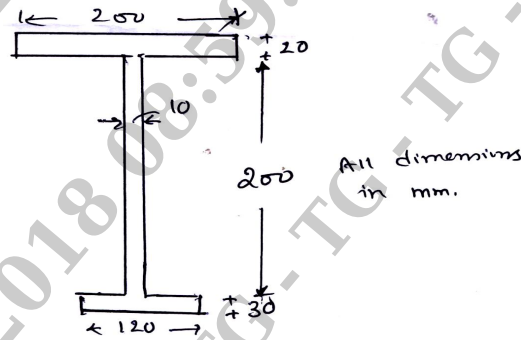

Fig. Q2(a)

- b. Determine plastic moment and draw BMD for collapse assuming M_p constant throughout for the beam as shown in Fig.Q2(b). (10 Marks)

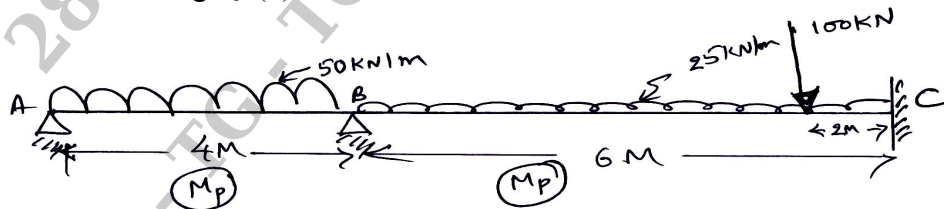

Fig. Q2(b)

Important Note : 1. On completing your answers, compulsorily draw diagonal cross lines on the remaining blank pages.
2. Any revealing of identification, appeal to evaluator and /or equations written eg. 42+8 = 50, will be treated as malpractice.

Module-2

- 3 a. The lower chord joint of a roof truss is as shown in Fig.Q3(a). Determine (i) Design strength of the bolt (ii) Number of bolts required to connect the angles to Gusset. Assume M20 bolts, $A_{sb} = 314 \text{ mm}^2$ and $A_{nb} = 245 \text{ mm}^2$. Assume $A_{sb} = 201 \text{ mm}^2$. (06 Marks)

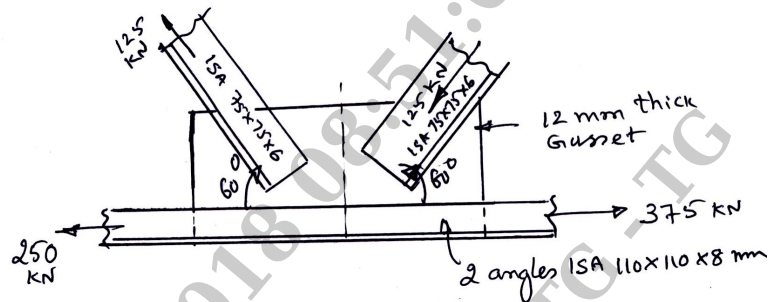

Fig.Q3(a)

- b. Determine the ultimate load carrying capacity in tension for the Lap Joint shown in Fig.Q3(b). Assume bolts threads are outside the shear plane. Adopt M16 bolts – Grade C of property class 4.6. Assume yield and ultimate strengths of the flats as 250 MPa and 410 MPa respectively. (10 Marks)

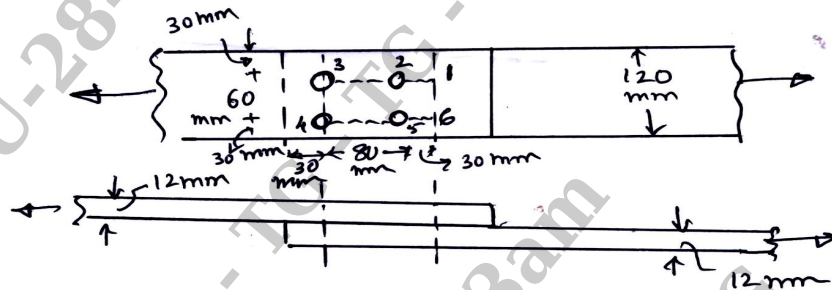

Fig.Q3(b)

OR

- 4 a. In a truss, ISA 100×100×8 mm is subjected to a factored tension of 200 kN. It is to be connected to a gusset using fillet welds at the toe and back. Find the lengths of welds required so that centre of gravity of welds lies in the plane of centre of gravity of the angle. Assume $f_u = 410 \text{ MPa}$. (08 Marks)
- b. Determine the size and effective length of the side fillets to connect two plates with cross sections of 150×10mm and 100×10 mm subjected to a tension of 125 kN (working load). Assume $f_u = 410 \text{ MPa}$. (08 Marks)

Module-3

- 5 a. Determine design load capacity of a single discontinuous angle ISA 50×50×5 mm used as a compression member in a roof truss connected to gusset by two bolts. Centre to centre distance between end connections is 1.5m. Adopt E250 steel. (08 Marks)
- b. Determine the design load carrying capacity of a discontinuous strut 2.50 m long comprising of two ISA 70×70×6 mm if connected to same side of 8mm gusset plate by more than one bolt in each angle. (08 Marks)

OR

- 6 a. Mention design specifications for Battening as per IS 800-2007. (04 Marks)
- b. Design single lacing system for a column of effective length 5 m to carry 900 kN axial loading. Adopt E250 grade steel. Also design suitable fillet welds. (12 Marks)

Module-4

- 7 Design the end connection for ISA 100×100×10 mm using lug angle for its full design strength. Adopt M20 bolts – Grade C, Property class 4.6. Provide E250 steel. Sketch the connection details. (16 Marks)

OR

- 8 a. Distinguish Slab base from Gusseted base. (02 Marks)
 b. Explain with neat sketch, components of a gusseted base. (04 Marks)
 c. Design a column splice using HSFG bolts of class 8.8 for the following details;
 Factored Axial force = 750 kN
 Factored Bending moment = 150 kN-m
 Factored shear force = 75 kN.
 Section of the column is SC250. Assume ends of the column are milled and bearing type connection are provided. (10 Marks)

Module-5

- 9 Design a simply supported I section to support the slab of a hall of 9m × 24m with beams spaced at 3 m c/c. slab is of 100mm thick. Consider floor finish load of 0.5 kN/m² and live load of 3 kN/m². Adopt E250 steel. Assume adequate lateral support to the compression flange. Also check for deflection. (16 Marks)

OR

- 10 Explain briefly ;
 a. Shear strength of steel beams
 b. Laterally unsupported beams
 c. Factors affecting lateral stability
 d. Column splices. (16 Marks)

* * * * *